

# Closed Ion Source Gas Analyzers

CIS100/200/300 — 100, 200 and 300 amu systems



## SRS Closed Ion Source Gas Analyzers

- **100, 200 and 300 amu systems**
  - **1 ppm detection**
  - **10 mTorr max. operating pressure**
  - **$1 \times 10^{-12}$  Torr detection limit**
  - **RGA Windows software**
  - **Multi-head operation**
  - **Field-replaceable electron multiplier and filament**
  - **RGA and CIS mode**
- 
- **CIS100/1 ... \$7250 (U.S. list)**
  - **CIS200/1 ... \$8000 (U.S. list)**
  - **CIS300/1 ... \$9500 (U.S. list)**

With better than 1 ppm detection limit, direct sampling at mTorr pressure and a user friendly Windows software package, the CIS systems will satisfy your most demanding applications. On-line process monitoring and control, verification of process gas purity at the point of use, high-vacuum residual gas analysis, and process equipment leak checking are some of the areas where these systems will prove indispensable.

### Compact Design

The probe consists of a quadrupole mass spectrometer with a CIS ionizer mounted inside a 2.75" Conflat® Tee. The control unit mounts directly on the probe's feedthrough flange and contains all the necessary electronics for operating the instrument. The side port of the CIS nipple provides a connection for the differential pumping system that keeps the quadrupole, filament and detector at high vacuum. The system can be connected directly to a process chamber through its standard CIS mounting flange (2.75" CF). All parts in the unit are self-aligning making servicing easy. You can clean and reassemble the probe, and replace the filament and electron multiplier in the field, without ever calling the factory.

### Gold Plated Ionizer

The entire ionizer is made of gold plated stainless steel. This reduces outgassing and background signals in the ionization region, improves long-term stability and permits operation



ASCII format for easy transfer into spreadsheets. Graphic images can be saved as META files or copied to the clipboard

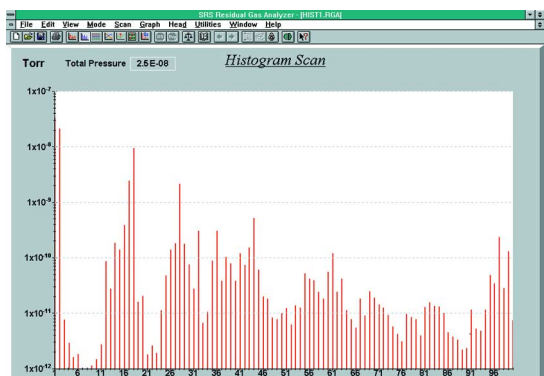

RGA Windows software—Histogram mode

for importing into other Windows programs. The software also provides password protection for locking out head parameters so that casual users can't alter important settings.

An optional stand-alone monitor (PPM100) can be used to control the RGA without a host computer.

### Multi-Head Operation

The software supports multiple head operation when more than one CIS is needed. Up to eight ECUs can be monitored from the software.

### Pumping Requirements

The CIS instruments require connection to a pumping system with an effective pumping speed of at least 40 L/s and a base pressure of less than  $10^{-9}$  Torr. The connection port is a 2.75" CF flange. Option O100TDP provides a turbo pump

which mounts directly to the CIS head along with a diaphragm roughing pump. When this option is ordered, the entire analyzer is assembled, tested, and calibrated at the factory. Users can provide their own pumping station; however, it is the user's responsibility to ensure that the pumping system does not damage or limit the performance of the instrument.

### Affordable Performance

The SRS CIS systems offer state-of-the-art performance for a fraction of the cost of competing models. Standard systems include faraday cup detector, electron multiplier detector and Windows software. Options include built-in power module for AC line operation and a pumping package that includes a turbomolecular pump and diaphragm pump.



CIS rear panel (without AC power module)



CIS rear panel (with AC power module)

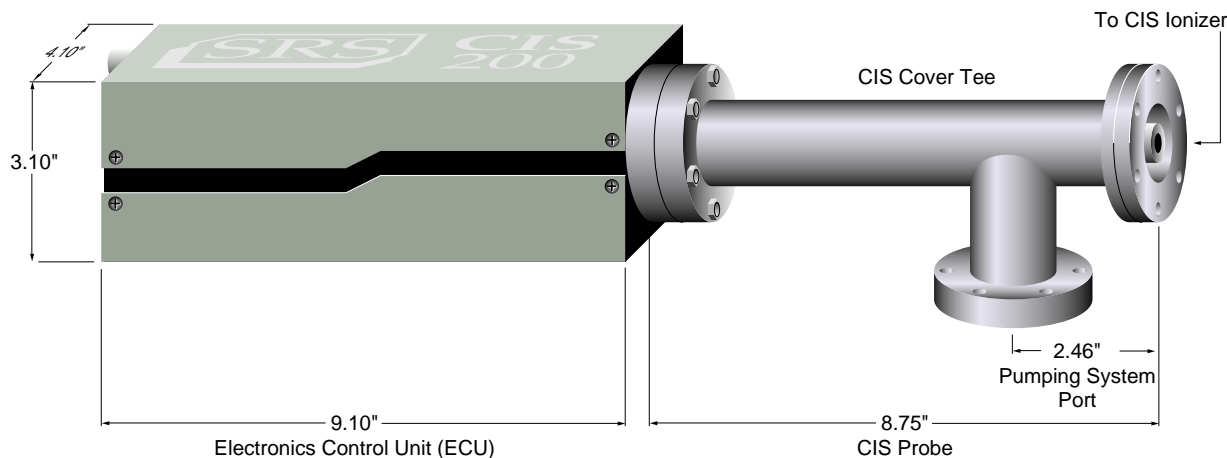

CIS dimensional drawing

**Operational**

Mass range	
CIS100/1	1 to 100 amu
CIS200/1	1 to 200 amu
CIS300/1	1 to 300 amu
Mass filter type	Quadrupole
Detector type	Faraday cup and electron multiplier
Resolution	Greater than 0.5 amu @ 10 % peak height. Adjustable to constant peak width throughout mass range.
(per AVS std. 2.3)	
Operating temperature	70 °C (max.)
Bakeout temperature	300 °C (without ECU)

Warm-up time	Peak height ±2 % after 3 minutes. Mass stability ±0.1 amu after 30 minutes.
Computer interface	RS-232C, 28,800 baud with high-level command set
Software	Windows based application
Power	24 VDC @ 2.5 amps. Male DB9 connector, optional built-in power module for AC line operation
Weight	6 lbs.
Warranty	One year parts and labor on defects in materials and workmanship

**Ionizer**

Design	Closed ion source, cylindrical symmetry, electron impact ionization.
Material	Gold plated SS304
Filament	Tungsten or ThO <sub>2</sub> /Ir with firmware protection (field replaceable)
Electron energy	25 to 105 eV, programmable
Ion energy	4 or 8 eV, programmable
Focus voltage	0 to 150 V, programmable
Electron emission current	0 to 1 mA, programmable

**General**

Probe mounting flange	2.75" CF
ECU dimensions	4.1" × 3.1" × 9.1" (WHD). Easily separated from the probe for bakeout.
Probe dimensions	See drawing
LED indicators	Power ON/OFF, filament ON/OFF, Electron multiplier ON/OFF, RS-232 Busy, Error, Overpressure, Burnt Filament

**Ordering Information**

CIS100/1	100 amu CIS w/ electron multiplier	\$7250
CIS200/1	200 amu CIS w/ electron multiplier	\$8000
CIS300/1	300 amu CIS w/ electron multiplier	\$9500
Option 02	AC power module	\$250
O100HJC	200 °C heater jacket	\$395
O100EM	Replacement electron multiplier	\$1000
O100RFT	2 replacement ThO <sub>2</sub> /Ir filaments	\$125
O100RFW	5 replacement tungsten filaments	\$100
O100RIC	Replacement ionizer kit (includes filament)	\$900
O100TDP	Turbo pump/diaphragm pump	\$9975
PPM100	Optional stand-alone monitor	\$2295

<b>CIS Parameter</b>	<b>Range</b>	<b>CIS mode</b>	<b>RGA mode</b>
Electron emission current (mA)	0 to 1	0.05	0.5
Electron energy (eV)	25 to 105	70 or 35	70
Ion energy (eV)	4 or 8	4 or 8	4 or 8
Extraction voltage (V)	0 to -150	-50 (typ.)	-50 (typ.)
Sensitivity (A/Torr) (for N <sub>2</sub> @ 28 amu)		10 <sup>-6</sup>	10 <sup>-5</sup>
Linear range upper limit (Torr)		2 × 10 <sup>-3</sup>	10 <sup>-4</sup>
MDPP (Torr)		10 <sup>-8</sup>	10 <sup>-9</sup>

**Notes**

1. The CIS tests were performed with a 70 L/s hybrid turbomolecular pump, backed by a diaphragm pump, attached to the side port of the CIS Cover Tee.
2. The RGA mode sensitivities reported were calculated for N<sub>2</sub> at less than 10<sup>-5</sup> Torr.
3. The CIS mode sensitivities were calculated for N<sub>2</sub> at 1 to 5 × 10<sup>-4</sup> Torr.
4. MDPP (minimum detectable partial pressure) is determined by measuring baseline levels for Faraday cup detection in the presence of <sup>28</sup>N<sub>2</sub> at 10<sup>-5</sup> (RGA mode) and 10<sup>-3</sup> Torr (CIS mode). Up to 3 orders of magnitude improvement in detectability is possible when the electron multiplier is turned on.

**Closed vs. Open Ion Source Gas Analyzers**

SRS RGAs use an Open Ion Source (OIS) configuration for ionization of gas molecules. The OIS extends into the process chamber and is "open" to all gaseous molecules in the vacuum environment. The pressure in the ionizer, mass filter and ion detector is the same as the pressure in the vacuum chamber. The maximum operating pressure for an OIS analyzer is  $10^{-4}$  Torr. However, the maximum pressure can be shifted up to about 10 Torr with the help of a pressure reducing gas inlet system (PPR). OIS analyzers have the sensitivity and dynamic range required to detect part-per-million (ppm) level contaminants. However, interferences from process gases and background outgassing from the sensor itself (i.e. the RGA) can make the detection of ppm levels of some common residual impurities, such as water, difficult.

In applications requiring the measurement of pressures between  $10^{-4}$  and  $10^{-2}$  Torr, the problem of background and process gas interferences with the mass spectra can be significantly reduced by replacing the traditional OIS PPR configuration with a Closed Ion Source (CIS) gas sampling system.

The CIS ionizer consists of a short, gas-tight tube with two small openings for the entrance of electrons and the exit of ions. Ions are produced by electron impact at the process pressure (mTorr range), while at the same time, a differential pumping system keeps the filament and the rest of the quadrupole assembly at pressures below  $10^{-5}$  Torr (two decades lower).

Because the sampling pressure in the CIS is typically two decades higher than that of the rest of the sensor's vacuum system, the signal-to-background ratio is significantly increased relative to the OIS PPR configuration.

To illustrate the difference between the two ionization configurations, we use (as an example) the measurement of water impurity levels in a  $10^{-3}$  Torr Ar sputtering process using both an OIS and a CIS gas analyzer.

An OIS cannot be exposed directly to 1 mTorr of process pressure. A PPR must be used to step the total pressure down to about  $10^{-5}$  Torr. The pressure drop brings a 1 ppm level of water in the process chamber (corresponding to a  $10^{-9}$  Torr partial pressure of the impurity) to a partial pressure of about  $10^{-11}$  Torr, well within the detection limit of a typical RGA. However, the residual pressure in the quadrupole is, at best,  $10^{-9}$  Torr with most of that being water. This water background level is one hundred times larger than the  $10^{-11}$  Torr corresponding to the 1 ppm of water coming from the process chamber. We conclude that water vapor in the process gas cannot be reliably measured to better than 100 ppm.

In the CIS system, the Ar gas is ionized directly at  $10^{-3}$  Torr without any intermediate pressure reduction. At the same time, the background water signal is the same or less than in the OIS configuration, since it is due to water molecules

backstreaming into the CIS ionizer from the quadrupole assembly (approx.  $10^{-9}$  Torr). This background water signal now corresponds to a 1 ppm water level in the process gas. The water vapor in the process gas can now be measured to better than 1 ppm (a two decade improvement).

The combination of direct sampling and differential pumping allows ppm and sub-ppm detection limits for even the most pervasive residual gases. For other common interferences, such as organic contaminants or reaction by-products of the filament, the gas-tight design of the source reduces the visibility of the ionization region to those gases, providing a very clean residual gas spectrum.

The ability of the CIS gas analyzer to sample in the mTorr range, and to provide ppm level detectability across its entire mass range, makes it ideal for semiconductor processing applications such as PVD, CVD and etching. However, the higher pressure limit of the CIS is achieved at the cost of an increased (two decades typical) minimum detectable partial pressure level relative to an OIS PPR.

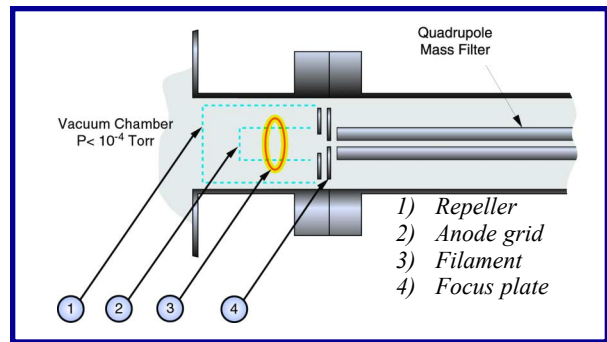

*Cross section of the SRS Open Ion Source (OIS)*

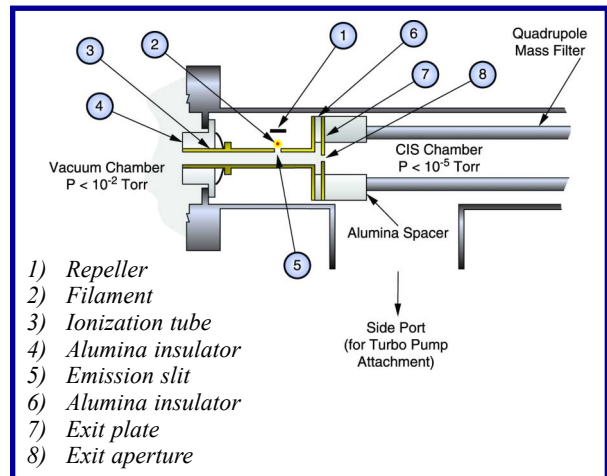

*Cross section of the SRS Closed Ion Source (CIS)*